

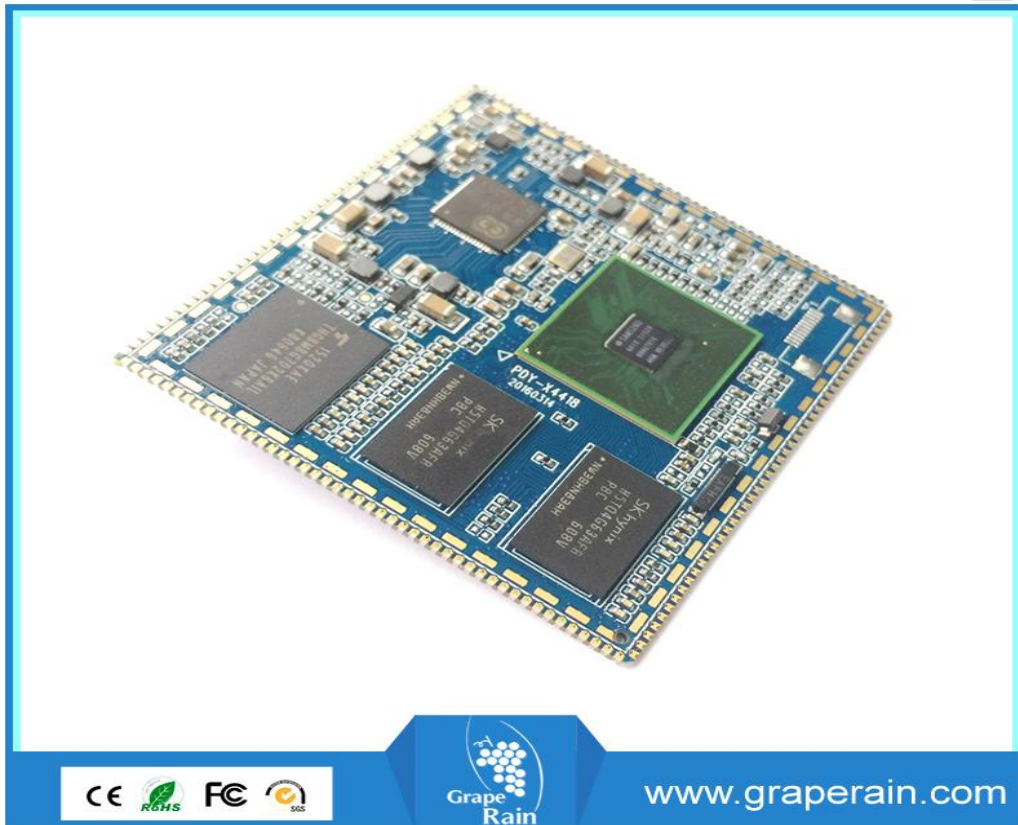

G4418 System on Module Introduction





深圳葡萄雨技术有限公司

专注于ARM9, ARM11, Cortex-A8, Cortex-A9开发, 为企业提供嵌入式解决方案



ARM方案行业案例
可信赖的ARM方案公司

Shenzhen Graperain Technology Co., Ltd.

<http://www.graperain.com/>

www.graperain.cn



Copyright Statement

Copyrights of this manual belong to Shenzhen Graperain Technology Co., Ltd. and all rights are reserved. Any companies or individuals are not allowed to extract part or all of this manual, and violators will be prosecuted under law.

Attention:

The manuals of development platform on sell will be updated from time to time, please download the latest manual from website www.graperain.com or contact our company sales representative, there would be no further notice.

www.graperain.cn



Release notes

Version	Release Date	Author	Description
Rev.01	2016-4-8	David Huang	Revision

www.graperain.cn



**Grape
Rain**

深圳葡萄雨技术有限公司

专注于ARM9, ARM11, Cortex-A8, Cortex-A9开发, 为企业提供嵌入式解决方案



ARM方案行业案例
可信的ARM方案公司

Technical Support

Any questions about the manuals, you can call our landline or email us.

Website: <http://www.graperain.com>

Landline: +86 755 23025312

E-mail: supports@graperain.com

Sales and service network

Shenzhen Graperain Technology Co., Ltd.

Website: <http://www.graperain.com>

Landline: +86 755 23025312

E-mail: sales@graperain.com

Address: Room 512, Building D, Huafeng Tech. & Innov. Park Baoan Wisdom Valley,
Xixiang, Baoan Dist. Shenzhen, Guangdong. Post code 518101.

Contents

Copyright Statement	3
Chapter 1 G4418 System on Module Introduction	7
1.1 G4418 System on Module Product Introduction.....	7
1.2 G4418 SOM Parameters	7
1.3 G4418 SOM Real View	9
1.4 G4418 SOM Structure.....	10
1.5 G4418 SOM Carrier Board Real View	11
Chapter 2 G4418 System on Module PINs Definitions.....	12
2.1 PIN Definitions 1	12
2.2 PIN Definitions 2	12
2.3 PIN Definitions 3	13
2.4 PIN Definitions 4	14
2.5 PIN Definitions 5	14
Chapter 3 G4418 System on Module Hardware Design.....	15
3.1 Power Design	15
3.2 USB Design.....	15
3.3 HDMI Design.....	15
3.4 LVDS Design	16
3.5 MIPI Design.....	16
Chapter 4 Product Portfolio	17
4.1 System on Modules	17
4.2 Development Boards.....	17
4.3 Single Board Computers	17

Chapter 1 G4418 System on Module Introduction

1.1 G4418 System on Module Product Introduction

G4418 system on module (for short G4418 SOM) is a new product platform based on Samsung S5P4418 (A9 quad-core) chip that designed by Shenzhen Graperain Technology Co., Ltd.

The G4418 SOM takes stamp hole system on module and based board. It is so strong expandability, supports 180PIN, running 1.4GHz. PCB designed 8 layers in immersion gold, and is of best electrical specification and anti-interference characteristic, and work stable. It inland PMU, and with coulombmeter charging, integrating the gigabit Ethernet firstly. The system on module could be used in MID, POS, PDA, PND, smart home, phone, learning machine, game machine and other kinds of industrial control filed.

G4418 SOM takes 28nm craftsmanship, built-in high performance A9 ARM Quad core architecture, compare with Exynos4412, S5P4418 supports mostly format video decoding, and inland LVDS and RGB double channels display control interface. Its resolution ratio is 2048*1280. Meanwhile it integrates the Gigabit Ethernet controller inside. More, G4418 delete some expensive function but useless. About electrical level, 4418 is 3.3V GPIO, and 4412 is 1.8V GPIO, obviously G4418 is more convenience for development products. And G4418 cost less in price.

G4418 SOM features as following:

- The best size: Ensure its bulk and size for GPIO interface, only 52mm*52mm;
- Taking AXP228PMU of X-power to ensure its stable and low cost;
- Supports so many Emmc, and default Toshiba 8GB Emmc (19nmMLC technology);
- Perform single channel DDR3, default 1GB, and 2GB optional;
- Supports power sleep wake up;
- Supports Android 5.1, Linux+qt, Ubuntu operating system;
- Inland the Gigabit Ethernet;
- G4418 SOM is more stable, and it could stay 7days working.

1.2 G4418 SOM Parameters

Parameters	
Appearance	Stamp hole
System on module dimensions	52mm*52mm*3mm
Pin pitch	1.1mm
Pin pad dimensions	1.3mm*0.7mm
Pin quantity	184 PIN
Layer	8 layer

System Configuration	
CPU	S5P4418
Frequency	Quad-core 1.4GHz
RAM	1G(Default)/2GB(Optional)



Flash	4GB/8GB(Default)/16GB eMMC
Power IC	AXP228, DVFS, coulombmeter
Ethernet	RTL8211, the gigabit Ethernet PHY

Interface parameters	
LCD	TTL, LVDS, MIPI
Touch	Capacitive screen, resistive screen
Audio	AC97/IIS, supports record and play
SD card	2 Channel SDIO output channel
Nand	Obsolete technology, did not lead to
EMMC	Onboard eMMC, no extra pin leaded
Ethernet	The Gigabit Ethernet PHY
USB host	1 Channel HOST2.0, 1 Channel HSIC
USB OTG	1 Channel OTG2.0
UART	4 Channel serial ports, Flow control
PWM	4 Channel PWM output
IIC	2 Channel IIC output
SPI	1 Channel SPI output
ADC	2 Channel ADC output
Camera	1 Channel BT656/BT601, 1 Channel MIPI output
HDMI	HD audio and video output interface, audio and video synchronization output
VGA	LCD output
Boot config.	No, the system on module boot automatically

Electrical Features	
Input voltage	3.7V~5.5V (suggest 5V output)
Output voltage	3.3V/4.2V (bottom power and battery)
Working temperature	-40~80 °C
Storage temperature	-30~70 °C

1.3 G4418 SOM Real View

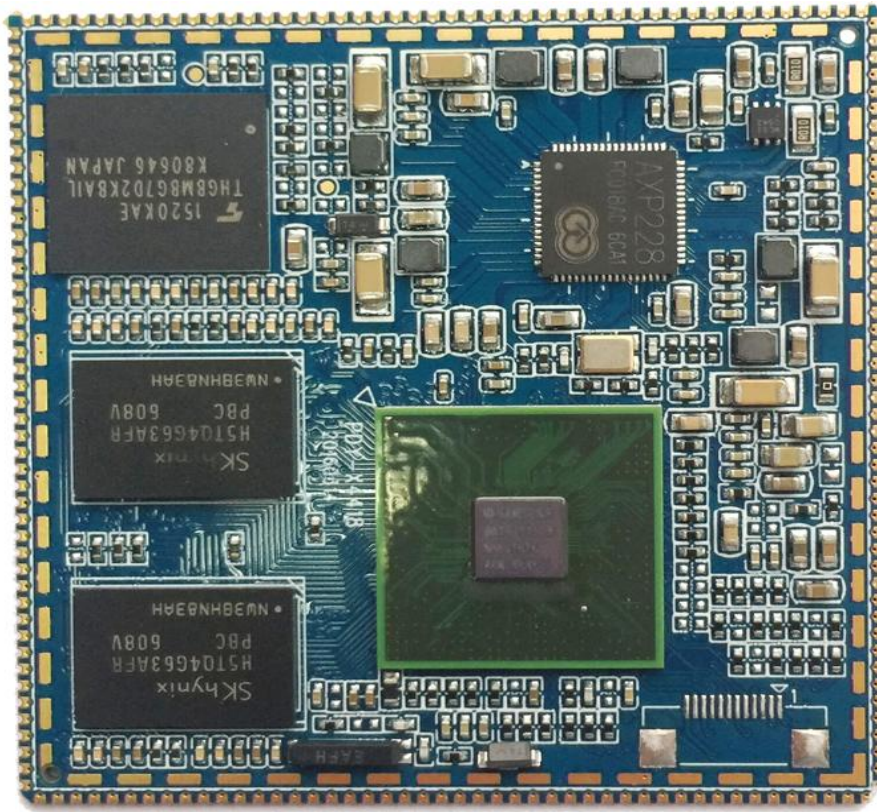

G4418 SOM Front View

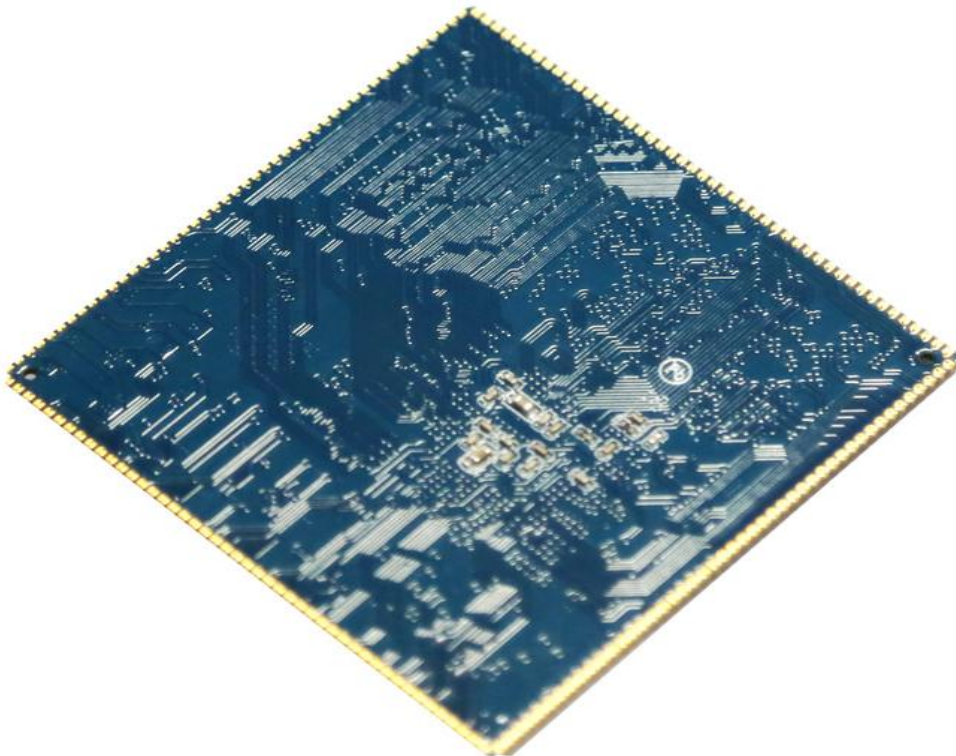

G4418 SOM Bottom View

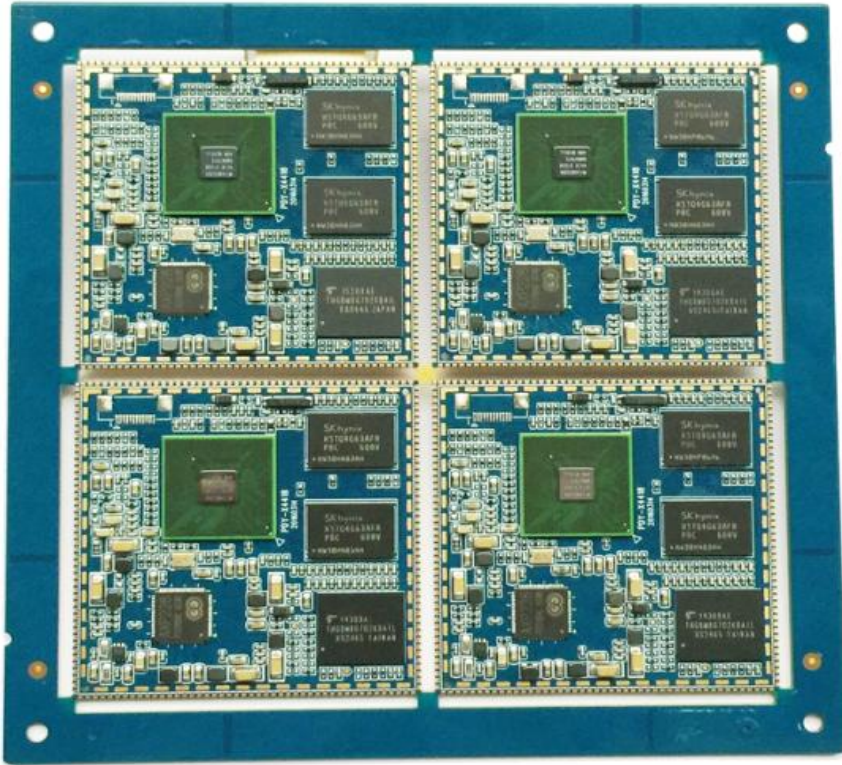

1.4 G4418 SOM Structure

G4418 SOM Structure and Dimensions:

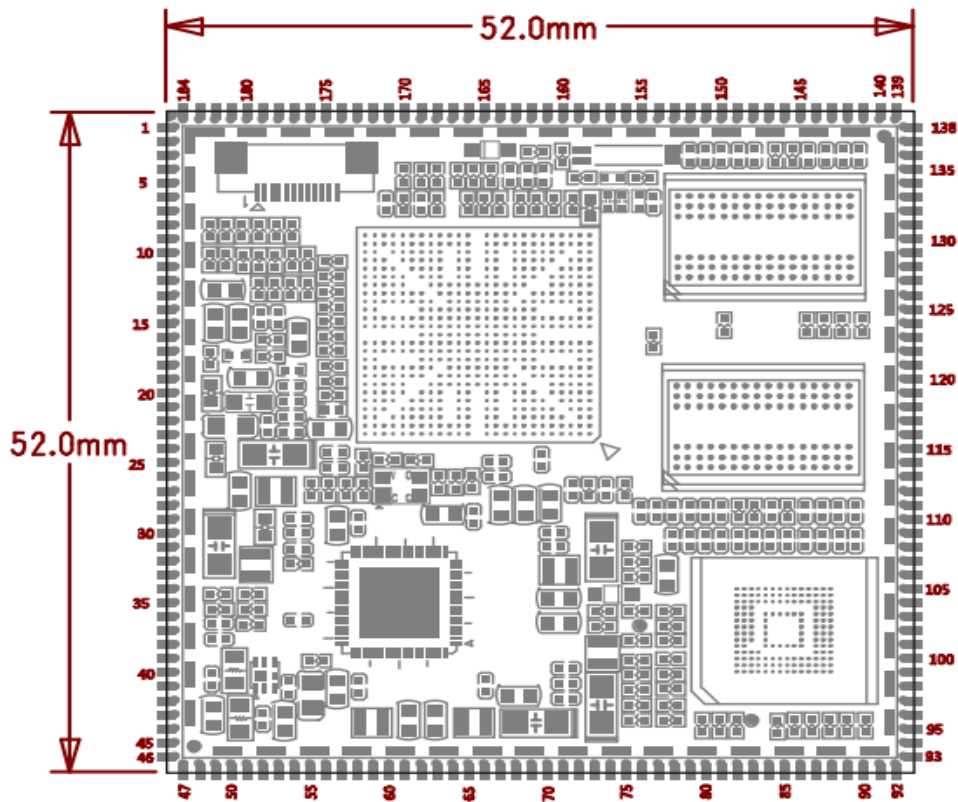



1.5 G4418 SOM Carrier Board Real View

Please reference G4418 development board files for detailed features.

www.graperain.cn

Chapter 2 G4418 System on Module PINs Definitions

2.1 PIN Definitions 1

PIN Definitions 1			
Pin#	Signal	Pin#	Signal
1	VCC3P3_SYS	24	LCD_R5
2	MCU_BACKLIGHT_PWM	25	LCD_R6
3	MCU_TOUCH_INT	26	LCD_R7
4	MCU_NRESETOUT	27	LCD_G0
5	MCU_VG_EN	28	LCD_G1
6	MCU_SDA_2	29	LCD_G2
7	MCU_SCL_2	30	LCD_G3
8	MCU_SDA_1	31	LCD_G4
9	MCU_SCL_1	32	LCD_G5
10	USBHSIC_DATA	33	LCD_G6
11	USBHSIC_STROBE	34	LCD_G7
12	MCU_USB_HOST_D-	35	LCD_B0
13	MCU_USB_HOST_D+	36	LCD_B1
14	MCU_OTG_PWRON	37	LCD_B2
15	MCU_USB-	38	LCD_B3
16	MCU_USB+	39	LCD_B4
17	DC5V_OTG	40	LCD_B5
18	MCU_USB_ID	41	LCD_B6
19	LCD_R0	42	LCD_B7
20	LCD_R1	43	LCD_DE
21	LCD_R2	44	LCD_HSYNC
22	LCD_R3	45	LCD_VSYNC
23	LCD_R4	46	LCD_CLK

2.2 PIN Definitions 2

PIN Definitions 2			
Pin#	Signal	Pin#	Signal
47	VCC1P0_CORE_DC	70	GMAC_MDIO
48	VCC1P0_CORE_DC	70	PHY_INT
49	VBAT	72	GMAC_TXD3
50	VBAT	73	GMAC_TXD2
51	GND	74	GMAC_TXD1
52	GND	75	GMAC_TXD0
53	VBAT_SYS	76	GMAC_TXEN
54	VBAT_SYS	77	GMAC_TXER

55	DCIN	78	MCU_SCL_0
56	DCIN	79	MCU_SDA_0
57	MCU_PWREN_SYS	80	MCU_HDMI_CEC
58	DLDO3	81	MCU_HDMI_HPD
59	DLDO2	82	MCU_HDMI_TXCN
60	ELDO3	83	MCU_HDMI_TXCP
61	GMAC_RXCLK	84	MCU_HDMI_TX0N
62	GMAC_TXCLK	85	MCU_HDMI_TX0P
63	GMAC_RXD0	86	MCU_HDMI_TX1N
64	GMAC_RXD1	87	MCU_HDMI_TX1P
65	GMAC_RXD2	88	MCU_HDMI_TX2N
66	GMAC_RXD3	89	MCU_HDMI_TX2P
67	GMAC_RXDV	90	GND
68	GMAC_MDC	91	MCU_LVDS_CLKM
69	PHY_RST	92	MCU_LVDS_CLKP

2.3 PIN Definitions 3

PIN Definitions 3			
Pin#	Signal	Pin#	Signal
93	MCU_LVDS_Y3M	116	MIPIDSI_DN1
94	MCU_LVDS_Y3P	117	MIPIDSI_DP1
95	MCU_LVDS_Y2M	118	MIPIDSI_DN0
96	MCU_LVDS_Y2P	119	MIPIDSI_DP0
97	MCU_LVDS_Y1M	120	MIPIDSI_DNCLK
98	MCU_LVDS_Y1P	121	MIPIDSI_DPCLK
99	MCU_LVDS_Y0M	122	MCU_I2S_MCLK
100	MCU_LVDS_Y0P	123	MCU_I2S_BCK
101	GND	124	MCU_I2S_SDIN
102	MIPIDSI_DP3	125	MCU_I2S_SDOUT
103	MIPIDSI_DN3	126	MCU_I2S_LRCK
104	MIPIDSI_DP2	127	MCU_HP_DET
105	MIPIDSI_DN2	128	CAM_H
106	MIPIDSI_DP1	129	CAM_V
107	MIPIDSI_DN1	130	CAM_CLK
108	MIPIDSI_DP0	131	CAM_D0
109	MIPIDSI_DN0	132	CAM_D1
110	MIPIDSI_DPCLK	133	CAM_D2
111	MIPIDSI_DNCLK	134	CAM_D3
112	MIPIDSI_DN3	135	CAM_D4
113	MIPIDSI_DP3	136	CAM_D5
114	MIPIDSI_DN2	137	CAM_D6

115	MIPIDSI_DP2	138	CAM_D7
-----	-------------	-----	--------

2.4 PIN Definitions 4

PIN Definitions 4			
Pin#	Signal	Pin#	Signal
139	CAM_PD	162	GPIOC7
140	CAM_RST	163	GPIOB8
141	CAM_PN	164	GPIOB9
142	MCU_CAM1_MCLK	165	GPIOC11
143	UARTRXD3	166	GPIOA28
144	UARTTXD3	167	PWM2
145	UARTRXD2	168	IR
146	UARTTXD2	169	VCCIP8_RTC
147	UARTRXD1	170	MCU_SD1_CD
148	UARTTXD1	171	MCU_SD1_CLK
149	UARTRXD0	172	MCU_SD1_CMD
150	UARTTXD0	173	MCU_SD1_D0
151	MCU_SPTXD0	174	MCU_SD1_D1
152	MCU_SPIFRM0	175	MCU_SD1_D2
153	MCU_SPICLK0	176	MCU_SD1_D3
154	MCU_SPIRXD0	177	MCU_SD0_CD
155	MCU_SPI_WP	178	MCU_SD0_D3
156	MCU_KEY_VOLDN	179	MCU_SD0_D2
157	MCU_KEY_VOLUP	180	MCU_SD0_D1
158	MCU_SEN0_INT	181	MCU_SD0_D0
159	MCU_NRSETIN	182	MCU_SD0_CMD
160	MCU_PWRKEY	183	MCU_SD0_CLK
161	ADC0	184	GND

2.5 PIN Definitions 5

Extended IO, the following part of g4418 system on module: 9 Available IO. (There is no CVBS_OUT on G4418, leads on G6818 system on module)

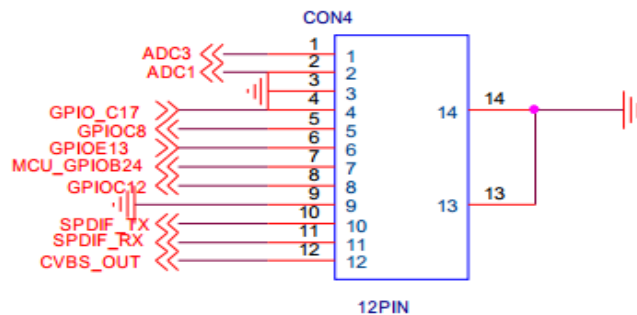

Chapter 3 G4418 System on Module Hardware Design

3.1 Power Design

G4418 system on module (for short G4418 SOM) PMU uses AXP228 launched by x-powers. G4418 SOM provide two ways of power input, one is through 5V/2A power input to power up to #55PIN and #56PIN; the other is 3.5 to 4.2 lithium battery power up to #49 PIN and #50 PIN. Both two ways could power up in same time, there is inland battery charge chip which play as controller of the power in/off. If taking power adapter power up, the electricity have to insure 1A as chip working peak. More, #53 PIN and #54 PIN are communal electrical level output interface for power adapter and battery, and its electrical level about 3.5V to 5V, and changes with outskirts power electrical level, and it could used to power up to its base board. #1 PIN is output interface for 3.3V power which could used to power up to its base board too, but when the system on module is in dormancy, 3.3V will power off, and its wake up voltage will return to normal. #169 PIN is power input interface, and its could connect with the backup battery, and to insure CPU clock not lose.

Kinds of voltages and corresponding PIN distribution as following:

#49 and 50PIN: Battery input interface, connect with 4.2V lithium battery, and it could be suspend when no battery.

#55 and 56 PIN: Power adapter input interface, 4.5 V to 5.5V input.

#53 PIN and 54 PIN: Battery and power adapter communal electrical level output interface, and its voltages based on battery and power adapter, which could be used to power up to its base board.

#169 PIN: The backup battery input, and if need RTC, the PIN will external connect with backup battery, and its voltages is 1.8V; Default the system on module power up to the PIN, but no keeping function when power off/ If no RTC needs, please suspend the PIN.

#1 PIN: 3.3V output interface, which could be used power up to base board. When system on module dormancy, the electrical level will off, and recover when wake up.

3.2 USB Design

G4418 SOM supports one HOST, one HSIC and one OTG. OTG could be used as HOST and DEVICE, it is a standard OTG. HOST could connect with USB peripheral, HSIC could bridging chip, such as USB3503, USB4640 and then transform it as standard HOST interface.

#12 and 13 PIN used through PCB, that USB_HOST_D, USB_HOST_D+ PIN is a differential pairs. #15 and 16 PIN too, and they are equolong differential pairs as its impedance matching is 90, if not, its USB transmission will not stable.

3.3 HDMI Design

G4418 SOM chip is of HDMI controller, and supports HDMI1.4. There is four equolong differential pairs from #82 to #89 PIN total eight Pins,4 pairs of differential lines, as its impedance matching is 100Ω , if not, HDMI pictures will lost color, and off and on etc.



3.4 LVDS Design

G4418 SOM is of LCD controller for GRB and LVDS interface. LVDS is a differential signal line, which drive high resolution LCD panel. It includes five sets transmission lines, and four set is data line in, its match #93 to #100 PIN; the other set is RTC line, match #91 and #92 PIN.

LVDS interface could provide high transmissibility, meanwhile low power dissipation. Its transmission rate could reach hundreds of Mbps to 2Gbps. And they are equilong differential lines as its impedance matching is 100Ω.

3.5 MIPI Design

G4418 SOM supports DSI and CSI, DSI match #102 to #111PIN, which used to connect with its display screen; CSI match #112 to #121 PIN, which used to connect with MINI interface Camera. The transmission rate of MIPI is higher than LVDS interface, and they are equilong differential lines as its impedance matching is 100Ω.

www.graperain.com

Chapter 4 Product Portfolio

4.1 System on Modules

G4418 System On Module (SoC is Samsung S5P4418)

G6818 System On Module (SoC is Samsung S5P6818)

G210 System On Module (SoC is Samsung S5PV210)

M9 System On Module (SoC is Qualcomm MSM8916)

G3288 System On Module (SoC is Rockchip RK3288)

4.2 Development Boards

G4418 Development board (SoC is Samsung S5P4418)

G6818 Development board (SoC is Samsung S5P4418)

G210 Development board (SoC is Samsung S5PV210)

M9 Development board (SoC is Qualcomm MSM8916)

G3288 Development board (SoC is Rockchip RK3288)

4.3 Single Board Computers

G4418 Single Board Computer (SoC is Samsung S5P4418)

G6818 Single Board Computer (SoC is Samsung S5P6818)

Instructions: For more detailed specifications and other products, please pay attention to www.graperain.com or contact us directly.